

Protect Your Process from Errors and Downtime



Double Protection

The redundant design protects your process from costly downtime. If there is a problem with one set of load cells or cables, the second set acts as a backup scale that allows you to continue weighing without the need to shut down the process.



Verified Accuracy

Each weigh module is equipped with two torsion-ring load cells that measure weight independently. Producing two weight readings provides the equivalent of a second scale that verifies weighing accuracy and repeatability. Load cells are available for class C3 or C6 (higher accuracy).



Hygienic Applications

RingMount® weigh modules are made of 316 stainless steel with a polished finish and no exposed threads. Their hygienic design inhibits the growth of bacteria and simplifies washdown, making the weigh modules ideal for clean-in-place applications.

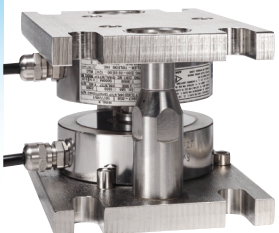

Safe Operation

Built-in checking is provided by hold-down bolts that limit the movement of each weigh module's top plate and restrain the tank from tipping. For most installations, no additional checking is needed.

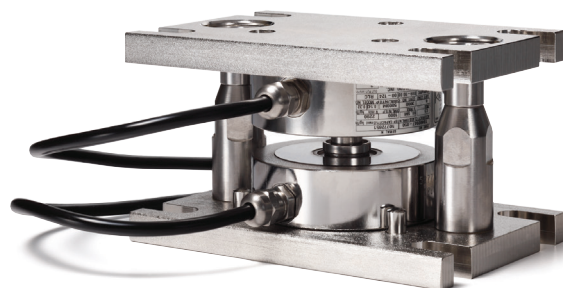

Redundant Weigh Module

Protect your process-weighing operation from costly weighing errors and downtime with a redundant RingMount® weigh module system. Essentially two scales in one, a redundant system produces duplicate weight readings to verify accuracy and provide backup weighing. RingMount® weigh modules are used for weighing tanks and vessels in the food, pharmaceutical, chemical, cosmetics, and biotech industries where hygiene is critical. Redundant weigh modules are designed for operations where profits depend on producing superior batches without waste or downtime. The more critical accuracy and repeatability are to your process, the more valuable a redundant weighing system is.

0970 Weigh Module Specifications

Weigh Module Parameter		Unit of Measure	Specification						
Model No.			0970 RINGMOUNT						
Rated Capacity		kg (lb, nominal)	250 (551)	500 (1,102)	1,000 (2,205)	2,000 (4,409)	3,500 (7,716)	5,000 (11,023)	10,000 (22,046)
Max. Top Plate Travel	Transverse	± mm (in)	2.3 (0.09)						
	Longitudinal	± mm (in)	2.3 (0.09)						
Restoring Force ¹		%A.L./mm (.../in) ⁶	17.7 (450)						
Max. Rated Forces									
Max. Compressive Force, Rated		kN (lb)	2.5 (551)	4.9 (1102)	9.8 (2205)	19.6 (4409)	34.3 (7718)	49 (11023)	98.1 (22046)
Max. Horizontal Force, Rated ²		kN (lb)	17.4 (3911)						26.7 (6002)
Max. Uplift Force, Rated ³		kN (lb)	15.1 (3394)						40.1 (9015)
Max. Yield Forces									
Max. Compressive Force, Yield		kN (lb)	3.7 (826.5)	7.4 (1653)	14.7 (3307.5)	29.4 (6613.5)	51.5 (11577)	73.5 (16534.5)	147.1 (33067.5)
Max. Horizontal Force, Yield		kN (lb)	24.2 (5440)						37.2 (8362)
Max. Uplift Force, Yield		kN (lb)	21 (4723)						55.8 (12544)
Max Ultimate Forces									
Max. Compression Force, Ultimate		kN (lb)	7.4 (1653)	14.7 (3306)	29.4 (6615)	58.8 (13227)	103 (23154)	147.1 (33069)	294.2 (66135)
Max. Horizontal Force, Ultimate		kN (lb)	25.9 (5822)						47.2 (10610)
Max. Uplift Force, Ultimate		kN (lb)	73 (16445)						175 (39439)
Weight (including load cells), nominal		kg (lb)	4.2 (9.3)						12 (26.4)
Material			316 stainless steel						

Load Cell Parameter		Unit of Measure	Specification						
Model No.			RLC						
Rated Capacity (R.C.)		kg (lb, nominal)	250 (551)	500 (1,102)	1,000 (2,205)	2,000 (4,409)	3,500 (7,716)	5,000 (11,023)	10,000 (22,046)
Rated Output		mV/V @ R.C.	1.75 ± 0.1	2 ± 0.1				2.05 ± 0.1	
Combined Error ^{4, 5}		%R.C.	C3: ≤ 0.018; C6: ≤ 0.013 ⁸						
Temperature Effect on	Min. Dead Load Output	%R.C./°C (.../°F)	C3: ≤ 0.0020 (0.0011); C6: ≤ 0.0012 (0.0006) ⁸						
	Sensitivity ⁵	%A.L./°C (.../°F)	C3: ≤ 0.0009 (0.0005); C6: ≤ 0.0004 (0.0002) ⁸						
Temperature Range	Compensated	°C (°F)	-10 to +40 (+14 to +104)						
	Operating	°C (°F)	-30 to +70 (-22 to +160)						
	Safe Storage	°C (°F)	-50 to +80 (-58 to +176)						
OIML/European Approval ⁷	Class		C3; C6 ⁸						
	nmax		C3: 3000; C6: 6000 ⁸						
	Y		C3: 7100; C6: 12050 ⁸						
NTEP Approval ⁷	Class		NA	III M; III L M				NA	
	nmax		NA	5000; 10,000				NA	
	Vmin	kg	NA	R.C./16,667; R.C./33,333				NA	
ATEX Approval ⁷	Rating		II 2 G EEx ib IIC T4 or T6 / II 2 D T70°C ; II 3 G EEx nL IIC T4 or T6 / II 3 D T70°C						
Factory Mutual Approval ⁷	Rating		IS/I,II,III/1/ABCDEF/T4 ; NI/II/2/ABCD/T6 ; S/II,III/2/FG						
Excitation Voltage	Recommended	V AC/DC	10						
	Maximum	V AC/DC	30						
Terminal Resistance	Excitation	Ω	1100 ± 50	1110 ± 50				1100 ± 50	
	Output	Ω	1025 ± 50	1025 ± 25				1025 ± 50	
Material	Spring Element		Stainless steel						
	Type		Glass-to-metal seal						
Protection	IP Rating		IP68						
	NEMA Rating		NEMA 6/6P						
Load Limit	Safe	%R.C.	150						
	Ultimate	%R.C.	150 ⁹						
Deflection @ R.C., nominal		mm (in)	0.1 (0.004)						
Weight, nominal		kg (lb)	0.73 (1.6)			0.96 (2.2)		1.2 (2.6)	
Cable Length		m (ft)	5 (16.4)				10 (32.8)		



Notes for Specifications Table

- ¹ % of Applied Load (A.L.) per mm (in) displacement of the top plate (transverse and longitudinal).
- ² Maximum horizontal force that can be applied to the top plate.
- ³ Maximum vertical uplift force that can be applied to the top plate.
- ⁴ Error due to the combined effect of non-linearity and hysteresis.
- ⁵ Typical values only. The sum of errors due to combined error and temperature effect on sensitivity comply with the requirements of OIML R60 and NIST HB44.
- ⁶ A.L. = Applied Load.
- ⁷ See certificate for complete information.
- ⁸ Class C6 load cells are available only in the following capacities: 1000, 2000, 3500, 5000 kg.
- ⁹ Applied load must not exceed 150% R.C. unless load cell is mounted on a ground metal surface (which is required for the overload protection to function).

0970 Weigh Module Dimensions

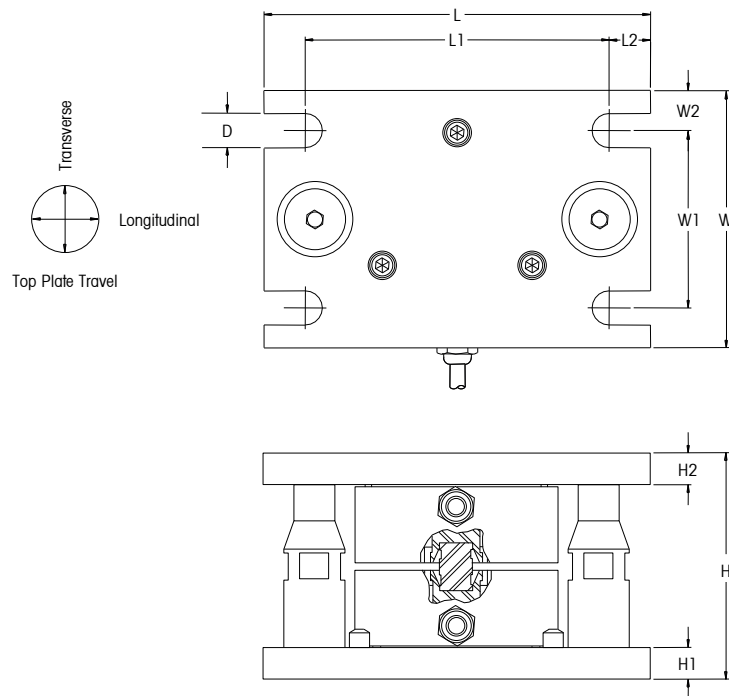

Note: Each weigh module is supplied with shipping/installation blocks to keep the top and bottom plates rigidly aligned during shipping and installation.

Capacity	D	H*	H1	H2	L	L1	L2	W	W1	W2
250-5,000 kg 551-11,023 lb	13.5 mm 0.53 in.	89.6 mm 3.53 in.	12.7 mm 0.50 in.	12.7 mm 0.50 in.	152.4 mm 6.00 in.	120.0 mm 4.72 in.	16.2 mm 0.64 in.	101.6 mm 4.00 in.	70.0 mm 2.75 in.	15.8 mm 0.62 in.
10,000 kg 22,046 lb	18.0 mm 0.71 in.	127.8 mm 5.03 in.	19.1 mm 0.75 in.	25.4 mm 1.00 in.	203.2 mm 8.00 in.	165.1 mm 6.50 in.	19.1 mm 0.75 in.	120.7 mm 4.75 in.	82.6 mm 3.25 in.	19.1 mm 0.75 in.

* Height when the weigh module is set up for weighing (shipping blocks removed). Shipping height is 90.4 mm (3.56 inches) and 128 mm (5.04 inches) respectively.

Top Plate Travel

Capacity	Longitudinal	Transverse
250-5,000 kg 551-11,023 lb	± 2.3 mm ± 0.09 in.	± 2.3 mm ± 0.09 in.

0970 Cable Colors

Color	Function
Pink	+ Excitation
Gray	- Excitation
Brown	+ Signal
White	- Signal
Clear	Shield

0970 Mounting Arrangements

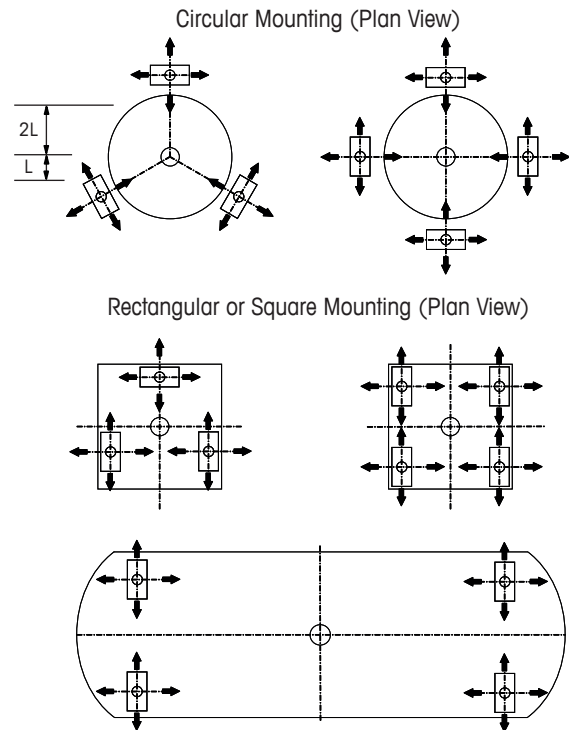

Note: Typical mounting arrangements are shown above. The weigh modules can be oriented in other directions as long as they are evenly spaced and each supports approximately the same weight.

0970 Weigh Module Ordering Information

Description	Item No.
0970 Redundant Weigh Module, 250 kg, C3, 316 Stainless Steel	61046846
0970 Redundant Weigh Module, 500 kg, C3, 316 Stainless Steel	61046848
0970 Redundant Weigh Module, 1,000 kg, C3, 316 Stainless Steel	61046850
0970 Redundant Weigh Module, 1,000 kg, C6, 316 Stainless Steel	61046861
0970 Redundant Weigh Module, 2,000 kg, C3, 316 Stainless Steel	61046855
0970 Redundant Weigh Module, 2,000 kg, C6, 316 Stainless Steel	61046860
0970 Redundant Weigh Module, 3,500 kg, C3, 316 Stainless Steel	61046856
0970 Redundant Weigh Module, 3,500 kg, C6, 316 Stainless Steel	61046859
0970 Redundant Weigh Module, 5,000 kg, C3, 316 Stainless Steel	61046857
0970 Redundant Weigh Module, 5,000 kg, C6, 316 Stainless Steel	61046858
0970 Redundant Weigh Module, 10,000 kg, C3, 316 Stainless Steel	30393968

Options	Item No.
Fabreeka Isolation Pad, 0970, 250-5,000 kg	61036187
Acetal Thermal Pad, 0970, 250-5,000 kg	61037314
Ultem PEI Thermal Pad, 0970, 250-5,000 kg	61037446

Description	Item Number
RLC Load Cell, 250 kg (C3)	61037713
RLC Load Cell, 500 kg (C3)	61038019
RLC Load Cell, 1000 kg (C3)	61036052
RLC Load Cell, 2000 kg (C3)	61037137
RLC Load Cell, 3500 kg (C3)	61037854
RLC Load Cell, 5000 kg (C3)	61038020
RLC Load Cell, 10000 kg (C3)	61038876
RLC Load Cell, 1000 kg (C6)	61038021
RLC Load Cell, 2000 kg (C6)	61037497
RLC Load Cell, 3500 kg (C6)	61038948
RLC Load Cell, 5000 kg (C6)	61037496

Global Approvals

Model RLC load cells have global certifications for metrological performance and hazardous area applications. There is no need for options or additional charges.

METTLER TOLEDO Service

Our extensive service network is among the best in the world and ensures maximum availability and service life of your product.



Weigh-Connect-Control-Comply

METTLER TOLEDO embeds intelligence into weighing applications. Our industry leading scale electronics enable users to integrate their gravimetric measurement with applications running on PCs, PLCs, or DCS systems. Our products are designed specifically for industries subject to regulatory controls, such as pharmaceutical, chemical, food and beverage, and have been confirmed by multiple global agency standards including UL, CE, NTEP, and OIML.

www.mt.com/weighmodule

For more information

Mettler-Toledo, LLC

1900 Polaris Parkway
Columbus, Ohio 43240
Tel. (800) 786-0038
(614) 438-4511
Fax (614) 438-4900

Specifications subject to change without notice.

© 2017 Mettler-Toledo, LLC
01/2019
30130002