

ICS466x

Weighing terminal

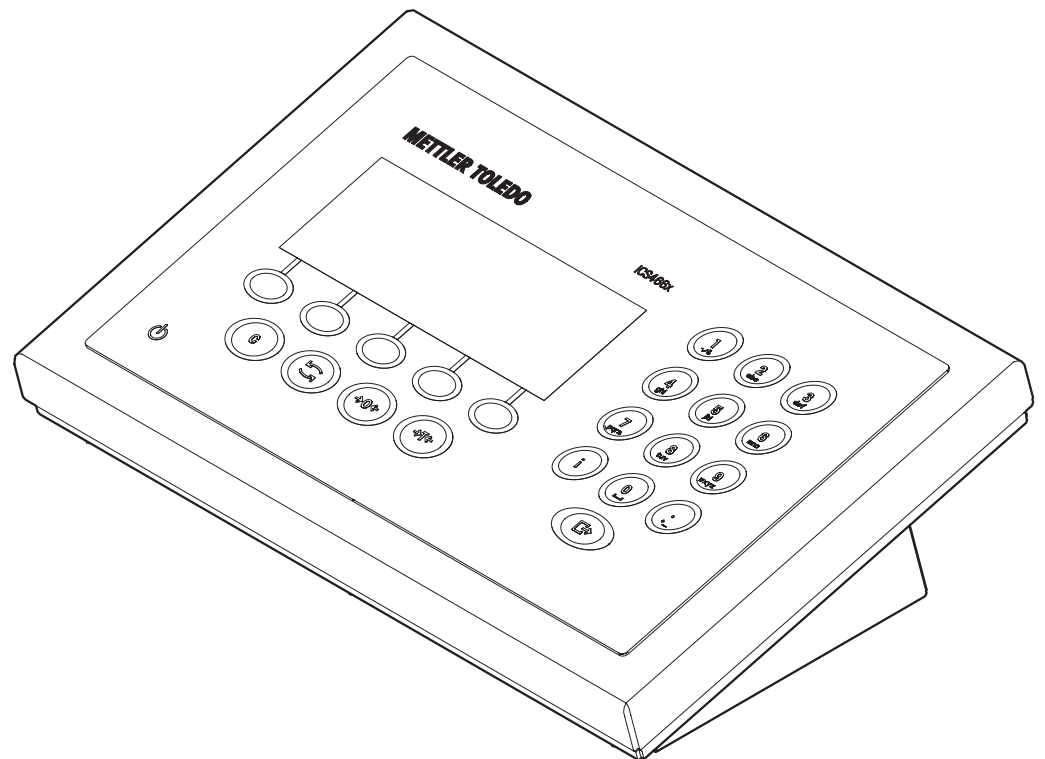

METTLER TOLEDO Service

Congratulations on choosing the quality and precision of METTLER TOLEDO. Proper use according to these instructions and regular calibration and maintenance by our factory-trained service team ensure dependable and accurate operation to protect your investment. Contact us about a service agreement tailored to your needs and budget.

We invite you to register your product at

www.mt.com/productregistration

so we can contact you about enhancements, updates and important notifications concerning your METTLER TOLEDO product.

Contents

1	Safety instructions.....	4
2	Settings in the menu.....	5
2.1	Operating the menu	5
2.2	Scale menu block – analog scales	8
2.3	Scale menu block – IDNet scales	12
2.4	Application menu block.....	15
2.5	Terminal menu block.....	23
2.6	Communication menu block	27
2.7	Maintenance menu block.....	33
3	Technical data and accessories.....	35
3.1	Technical data	35
3.2	Accessories.....	37
4	Appendix	38
4.1	Notice for verified instruments in EC countries.....	38
4.2	Tables of Geo Code values.....	38
4.3	Disposal	40
4.4	Protocol printouts	41
4.5	Index.....	42

1 Safety instructions



The ICS466x weighing terminal is approved for operation in Zone 1 and 21 hazardous areas as well as for Division 1 areas.

If the ICS466x weighing terminal is used in hazardous areas, special care must be taken. The code of practice is oriented to the "Safe Distribution" concept drawn up by METTLER TOLEDO.

- Competence**
- ▲ The weighing system may only be installed, maintained and repaired by authorized METTLER TOLEDO service personnel.
 - ▲ The mains supply may only be installed by a specialist authorized by the operating company.
- Ex approval**
- ▲ No modifications may be made to the terminal and no repair work may be performed on the modules. Any weighing platform or system modules that are used must comply with the specifications contained in the installation instructions. Non-compliant equipment jeopardizes the intrinsic safety of the system, cancels the "Ex" approval and renders any warranty or product liability claims null and void.
 - ▲ The safety of the weighing system is only guaranteed when the weighing system is operated, installed and maintained in accordance with the respective instructions.
 - ▲ Also comply with the following:
 - the instructions for the system modules,
 - the regulations and standards in the respective country,
 - the statutory requirement for electrical equipment installed in hazardous areas in the respective country,
 - all instructions related to safety issued by the owner.
 - ▲ The explosion-protected weighing system must be checked to ensure compliance with the requirements for safety before being put into service for the first time, following any service work and every 3 years, at least.
- Operation**
- ▲ Do not modify the weighing system.
 - ▲ Prevent the build-up of static electricity.
 - Always wear suitable working clothes when operating or performing service work in a hazardous area.
 - Only use the weighing terminal when electrostatic processes leading to propagating brush discharges are impossible.
 - ▲ Do not use protective covers for the devices.
 - ▲ Protect the keyboard membrane against ultraviolet radiation.
 - ▲ Avoid damage to the system components.

2 Settings in the menu

In the menu, settings can be changed and functions can be activated. This enables adaptation to individual weighing requirements.



The menu consists of the following 5 main blocks containing various submenus on several levels.



Scale	see section 1.2 (analog scales) and section 1.3 (IDNet scales)
Application	see section 1.4
Terminal	see section 1.5
Communication	see section 1.6
Maintenance	see section 1.7

2.1 Operating the menu

2.1.1 Calling up the menu and entering the password

The menu differentiates between 2 operating levels: Operator and Supervisor. The Supervisor level can be protected by a password.

- Operator access**
1. Press  and keep it pressed until `Enter code` appears.
 2. Press  again.
The menu item `Terminal` is displayed. Only parts of the submenu `Device` are accessible.

- Supervisor access**
1. Press  and keep it pressed until `Enter code` appears.
 2. Enter the password and confirm with .
- The first menu item `Scale` is highlighted.



- No supervisor password has been defined when the device is first delivered. Therefore, confirm the password inquiry with  when you call up the menu for the first time.
- As long as no supervisor password is defined, operator access will offer the complete supervisor menu.
- If a password has still not been entered after a few seconds, the scale returns to the weighing mode.

Emergency password for Supervisor access to the menu

If a password has been issued for Supervisor access to the menu and you have forgotten it, you can still enter the menu:

- Press **→0←** 3 times and confirm with .

2.1.2

Display presentation in the menu

Menu items are displayed together with their context.

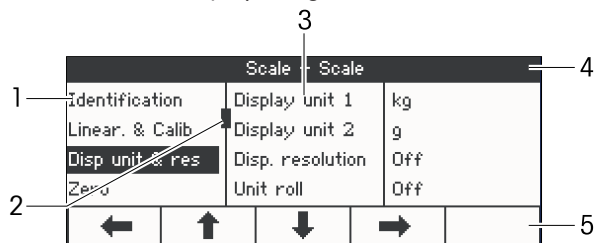

- 1 Menu items; the selected menu item is highlighted
- 2 Scroll flag, like the scroll bar of your PC
- 3 Sub-menu items
- 4 Menu info line, i.e., menu path of the current menu item
- 5 Soft key line: use the soft keys below to navigate the menu as indicated

Exiting the menu

1. Press **ON**.
"Save settings ?" is displayed.
2. Press **OK**.
The menu changes are saved and the terminal returns to the weighing mode.
– or –
- Press **ESC** for further menu settings.
– or –
- Press **NO** to discard changes and return to the weighing mode.

2.1.3 Selecting and setting parameters in the menu

Example: Setting of the average weighing mode to automatic

- In the menu start screen use **↓** to select (highlight) the `Application` menu.
The submenus are displayed in the middle column.

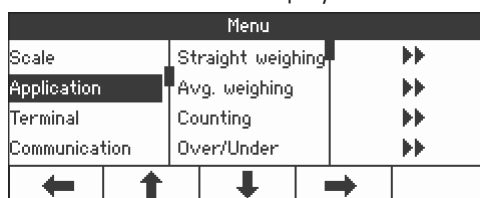

- Press **→** to enter the `Application` menu.

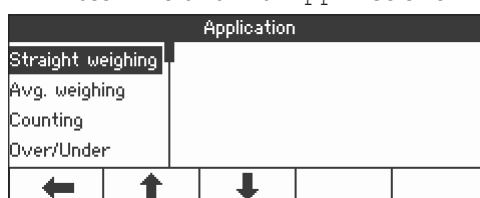

- Press **↓** and then press **→** to open the `Avg. weighing` submenu.
The current setting of the highlighted menu item is displayed in the right column.

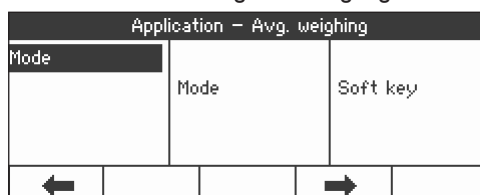

- Press **→** to enter the `Mode` submenu.
The possible settings of the selected menu item are displayed on the right side.

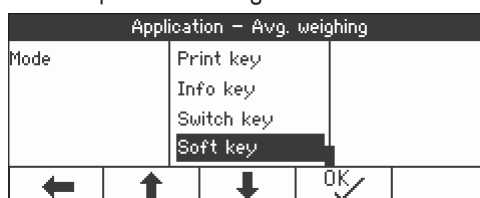

- Press **↓** to select (highlight) `Auto` and confirm selection with **OK**.
The setting of the average weighing mode has changed.

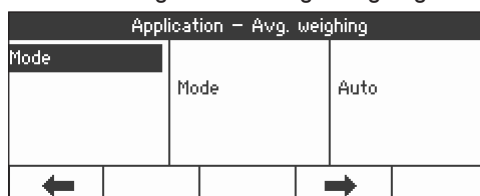

If all the settings of a menu item cannot be displayed on one page (e.g., all the info items), just use **↓** to proceed to the hidden items.

2.2



Scale menu block – analog scales

When entering the SCALE menu block, an overview of the connected scales is displayed:

2.2.1

Menu overview

After selecting the Scale 1 or Scale 2, the following menu is available for an analog scale. Factory settings are printed in **bold** in the following overview.

Level 1	Level 2	Level 3
Identifica- tion	Serial no. scale, Scale model, Scale location, Scale ID	
Linear. & Calib.	Last calibration	
	Auto print calib.	Off, On
	Perform calib.	
Disp unit & res	Display unit 1	g, kg , oz, lb, lb-oz, t
	Display unit 2	g , kg, oz, lb, lb-oz, t
	Disp. resolution	
	Unit roll	Off , On
Zero	AZM	Off, 0.5 d , 1 d, 2 d, 5 d, 10 d
Tare	Auto tare	Off , On
	Chain tare	Off, On
	Auto clear tare	Off , On
Restart	Off , On	
Filter	Vibration	Low, Medium , High
	Process	Universal , Dosing
	Stability	Fast, Standard , Precise
MinWeigh	MinWeigh	Off , On
	Set value	
	Display color	Yellow, light blue, dark blue, red , purple, green, orange, light green, pink, white
Reset	Perform reset ?	

2.2.2 Description of the (analog) Scale menu block

(Analog) Scale → Identification

Serial no. scale	Displaying the serial number of the weighing platform
Scale model	Displaying the scale type, e.g., PBA430x Available for METTLER TOLEDO scales only
Scale location	Entering the scale location, e.g., floor and room
Scale ID	Entering the scale identification, e.g., inventory number
Notes	<ul style="list-style-type: none"> Scale location and scale ID can be displayed in the auxiliary or info lines or printed out. Scale location and scale ID can consist of up to 24 alphanumeric characters.

(Analog) Scale → Linear. & Calib.

This menu item is not available for verified scales.

Last calibration	Displaying the date of the last calibration
Auto print calib.	If set to On , the calibration data will be printed out automatically after every calibration procedure.
Perform calib. Preload blinking xx kg blinking Preload blinking	<ol style="list-style-type: none"> Start calibration with the soft key OK. Unload the scale and confirm with the soft key OK. If necessary, change the calibration weight value displayed using ↓ / ↑. Put on the indicated calibration weight on the weighing platform and confirm with the soft key OK. Remove the calibration weight and confirm with the soft key OK. Passed is displayed briefly.
Note	<ul style="list-style-type: none"> In order to achieve a particularly high precision, calibrate under full load. The calibration process can be aborted using the soft key Esc.

(Analog) Scale → Displ. unit & res – Weighing unit and display accuracy

Unit 1	Select weighing unit 1
Unit 2	Select weighing unit 2
Resolution	Select readability (resolution), the possible settings depend on the connected scale.
Unit roll	When unit roll is switched on, the weight value can be displayed in all available units with  .
Notes	<ul style="list-style-type: none"> In case of verified scales, individual sub-items of the Displ. unit & res menu item may not be available or only to a limited extent, depending on the respective country. On dual-range/dual interval scales, resolutions marked with 1<->1 1/2 are divided up into 2 weighing ranges/intervals, e.g., 2 x 3000 d.

(Analog) Scale → Zero – Automatic zero update

AZM	<p>Automatic Zero Maintenance On verified scales, this menu item does not appear. Switching on/off automatic zero update and selecting zeroing range in digits per second. Possible settings: Off; 0.5 d; 1 d; 2 d; 5 d; 10 d</p>
------------	---

(Analog) Scale → Tare – Tare function

Auto tare	Switching on/off automatic taring
Chain tare	Switching on/off chain tare
Auto clear tare	<p>Switching on/off automatic clearing of the tare weight when the load is removed from the scale.</p> <ul style="list-style-type: none"> • On The tare weight is automatically cleared if the gross weight is 0 or below zero • Off No automatic clearing of the tare weight

(Analog) Scale → Restart – Automatic saving of zero point and tare value

Restart	<p>When the restart function is activated, the last zero point and the tare value are saved. After switching off/on or after a power interruption, the device continues to work with the saved zero point and tare value.</p>
----------------	---

**(Analog) Scale → Filter –
Adaptation of the ambient conditions and the weighing type**

<p>Vibration</p> <p>Low</p> <p>Medium</p> <p>High</p>	<p>Adaptation to ambient conditions</p> <ul style="list-style-type: none"> • Very steady and stable environment. The scale works very rapidly, but is very sensitive to external influences. • Normal environment. The scale operates at medium speed. • Restless environment. The scale works more slowly, but is insensitive to external influences. 						
<p>Process</p> <p>Universal</p> <p>Dosing</p>	<p>Adaptation to the weighing process</p> <ul style="list-style-type: none"> • Universal setting for all weighing samples and normal weighing goods. • Dispensing liquid or powdery weighing samples. 						
<p>Stability</p> <p>Fast</p> <p>Standard</p> <p>Precise</p>	<p>The slower the scale works, the greater the reproducibility of the weighing results.</p> <table> <tr> <td>Rapid</td> <td>Good reproducibility</td> </tr> <tr> <td>↑</td> <td>↓</td> </tr> <tr> <td>Slow</td> <td>Excellent reproducibility</td> </tr> </table>	Rapid	Good reproducibility	↑	↓	Slow	Excellent reproducibility
Rapid	Good reproducibility						
↑	↓						
Slow	Excellent reproducibility						

(Analog) Scale → MinWeigh – Minimum weighing-in quantity

MinWeigh	Switching minimum weight function on/off If the weight on the scale drops below the stored minimum weight,  appears in the symbols and info line.
Set value	Enter minimum weighing-in quantity
Display color	Selecting color for displaying an weight value below the minimum weighing-in quantity

(Analog) Scale → Reset – Resetting scale settings to factory settings

Perform reset ?	Confirmation inquiry <ul style="list-style-type: none">• Reset the analog scale settings to factory settings with the soft key OK.
------------------------	--

2.3**Scale menu block – IDNet scales**

When entering the SCALE menu block, an overview of the connected scales is displayed:

2.3.1**Menu overview**

After selecting the Scale 1 or Scale 2, the following menu is available for an IDNet scale: Factory settings are printed in **bold** in the following overview.

Level 1	Level 2	Level 3
Identifica- tion	Serial no. scale, Scale model, Scale location, Scale ID	
Display/ Units	Unit 2	g , kg, oz, lb, t
	Unit roll	Off , On
Zero	AZM	Off, On
Tare	Auto tare	Off , On
	Chain tare	Off, On
	Auto-Clear tare	Off , On
Restart	Off , On	
Filter	Vibration	Low, Medium , High
	Process	Universal , Dosing, Absolute
	Stability	ASD=0, ASD=1 , ASD=2, ASD=3, ASD=4
Update	5, 10, 20	
MinWeigh	MinWeigh	Off , On
	Set value	
	Display color	Yellow, light blue, dark blue, red , purple, green, orange, light green, pink, white
Reset	Perform reset?	

2.3.2 Description of the (IDNet) Scale menu block

(IDNet) Scale → Identification

Serial no. scale	Displaying the serial number of the weighing platform
Scale model	Displaying the scale type, e.g., Kx...T4
Scale location	Entering the scale location, e.g., floor and room
Scale ID	Entering the scale identification, e.g., inventory number
Notes	<ul style="list-style-type: none"> • Scale location and scale ID can be displayed in the auxiliary or info lines or printed out. • Scale location and scale ID can consist of up to 24 alphanumeric characters.

(IDNet) Scale → Display – Weighing unit

Unit 2	Select weighing unit 2: g, kg, oz, lb, t
Unit roll	When unit roll is switched on, the weight value can be displayed in all available units with  .
Notes	<ul style="list-style-type: none"> • In case of verified scales, individual sub-items of the <code>Display</code> menu item may not be available or only to a limited extent, depending on the respective country. • On multi-range/multi-interval scales, the symbol I<->I with number indicates the current range or interval.

(IDNet) Scale → Zero – Automatic zero update

AZM	<p>Automatic Zero Maintenance</p> <p>On verified scales, this menu item does not appear.</p> <p>Switching on/off automatic zero update.</p> <p>The maximum speed in digits per second of the automatic zero maintenance function (0.5 d; 1 d; 2 d; 3 d) can only be set by a service technician.</p>
------------	--

(IDNet) Scale → Tare – Tare function

Auto tare	Switching on/off automatic taring
Chain tare	Switching on/off chain tare
Auto-Clear tare	<p>Switching on/off automatic clearing of the tare weight when the load is removed from the scale.</p> <ul style="list-style-type: none"> • On The tare weight is automatically cleared if the gross weight is 0 or below zero • Off No automatic clearing of the tare weight

(IDNet) Scale -> Restart – Automatic saving of zero point and tare value

Restart	When the Restart function is activated, the last zero point and the tare value are saved. After switching off/on or after a power interruption, the device continues to work with the saved zero point and tare value.
----------------	--

(IDNet) Scale -> Filter –**Adaptation to the ambient conditions and the weighing type**

Vibration Low Medium High	Adaptation to the ambient conditions <ul style="list-style-type: none"> • Very steady and stable environment. The scale works very rapidly, but is very sensitive to external influences. • Normal environment. The scale operates at medium speed. • Restless environment. The scale works more slowly, but is insensitive to external influences. 																		
Process Universal Dosing Absolute	Adaptation to the weighing process <ul style="list-style-type: none"> • Universal setting for all weighing modes and normal weighing goods. • Dispensing of liquid or powdered weighing samples. • For solid bodies under extreme conditions, e.g., strong vibrations. 																		
Stability ASD = 0 ... ASD = 4	Adjusting stability monitoring <table> <tr> <td>ASD = 0</td> <td>Stability monitoring switched off</td> <td></td> </tr> <tr> <td></td> <td>Only possible for non-verified scales</td> <td></td> </tr> <tr> <td>ASD = 1</td> <td>Rapid</td> <td>Good reproducibility</td> </tr> <tr> <td>ASD = 2</td> <td>↑</td> <td>↓</td> </tr> <tr> <td>ASD = 3</td> <td>↑</td> <td>↓</td> </tr> <tr> <td>ASD = 4</td> <td>Slow</td> <td>Excellent reproducibility</td> </tr> </table>	ASD = 0	Stability monitoring switched off			Only possible for non-verified scales		ASD = 1	Rapid	Good reproducibility	ASD = 2	↑	↓	ASD = 3	↑	↓	ASD = 4	Slow	Excellent reproducibility
ASD = 0	Stability monitoring switched off																		
	Only possible for non-verified scales																		
ASD = 1	Rapid	Good reproducibility																	
ASD = 2	↑	↓																	
ASD = 3	↑	↓																	
ASD = 4	Slow	Excellent reproducibility																	
Note	The possible settings depend on the connected scale.																		

(IDNet) Scale -> Update – Setting the display speed of the weight display

This menu item is only displayed if the UPDATE function is supported by the connected scale.

xx UPS	Selecting the number of updates per second (UPS)
Note	The possible settings depend on the connected scale. Sent from the IDNet scale to the ICS466x display, the update rate might be lower.

(IDNet) Scale -> MinWeigh – Minimum weighing-in quantity

MinWeigh	Switching minimum weight function on/off If the weight on the scale drops below the stored minimum weight,  appears in the symbols and info line.
Set value	Enter minimum weighing-in quantity
Display color	Selecting color for displaying an weight value below the minimum weighing-in quantity

(IDNet) Scale -> Reset – Resetting scale settings to factory settings

Perform reset ?	Confirmation inquiry <ul style="list-style-type: none">Reset the IDNet scale settings to factory settings with the soft key OK.
------------------------	--





2.4 Application menu block

Factory settings are printed in **bold** in the following overview.

2.4.1 Application -> Straight weighing

Printout	Defining printer and template in the straight weighing application
COM1 ... COM2	Selecting the COM port for the desired printer in the safe area
Off	No printout on this COM port
Standard	Printout with the standard template on the selected printer
Template 1 ... Template 5	Assigning a customer template to the selected printer
Note	<ul style="list-style-type: none">There are 5 more templates available (Template 6 ... Template 10). Please ask your METTLER TOLEDO service technician to configure these templates, if desired.Templates 1 ... 5 can be defined under <code>Communication -> Define templates</code>

2.4.2 Application → Average weighing





Mode	Selecting mode for determining the average weight for an unstable load (dynamic weighing)
Auto	Calculating average weight with automatic start of the weighing cycle
Print key Info key Switch key Soft key	Calculating average weight with manual start of the weighing cycle via the selected key. Print key  Info key  Switch key  Soft key 
Printout	Defining printer and template in the average weighing application
	See "Straight weighing"

2.4.3 Application → Counting

Overview

Level 1	Level 2	Level 3
Reference size		
Fixed ref. Size	Off , On	
Ref weight	Ref. wt. check	Off , On
	Ref. wt. value	0 % ... 30 %
APW optimization	Off , Auto, Soft key	
Autosampling	Off , On	
Auto clear APW	Off , On	
Counting system	Scale 1	Bulk, Reference, Aux., Off
	Scale 2	
Printout	see "Straight Weighing"	

Description

Reference size	Defining a default reference size for soft key VAR
	E.g., when entering a reference size of 12 PCS, this reference size is displayed in the soft key  VAR.
Fixed ref. size	Reference size options for soft key VAR
Off	Variable reference size, i.e., any number of parts can be used as reference size with soft key  VAR.
On	Determining the average piece weight is only possible with the default reference size.
Ref Weight	Monitoring the minimum reference weight
Ref wt check	Activating/deactivating the reference weight check function.
Off	No monitoring of the minimum reference weight.
On	Monitoring the minimum reference weight. When the minimum reference weight drops below the set tolerance value, the display color changes and a message is displayed which asks you to add more reference parts. Minimum reference weight = 0.8 d / reference weight value
Ref wt value	Only displayed if Ref wt check is set to On.
1 % ... 30 %	Setting the factor for the reference weight check. The higher the factor, the smaller the required minimum reference weight. Factory setting: 20 %
APW optimization	Optimization of the average piece weight.
Off	No optimization of the average piece weight
Auto	Automatic optimization of the average piece weight
Soft key	Manual optimization of the average piece weight with soft key  ✓.
Autosampling	Automatic determination of the average piece weight
On	After taring, the average piece weight is determined with the next weight placed on the scale and the displayed reference size.
Off	No automatic determination of the average piece weight
Auto clear APW	Automatic clearing of the average piece weight
On	When the load is taken off the scale after a counting operation, the average piece weight is automatically cleared. The next counting operation begins with determining the average piece weight again.
Off	The average piece weight must be cleared manually with C .

Counting system	Configuring a system of several scales for counting
Scale 1, Scale 2	This menu item is available only if two scales are connected. Selecting the scale to assign a function in the counting system. Only the scales connected are displayed.
Bulk	The selected scale serves as bulk scale to count/measure quantities. Another scale of the system must then be set to <i>Reference</i> .
Reference	The selected scale serves as reference scale to determine the average piece/unit weight. Another scale of the system must then be set to <i>Bulk</i> .
Aux.	The selected scale can be used for determining the average piece/unit weight as well as for counting/measuring.
Off	The selected scale is not part of a counting system.
Printout	Defining printer and template in the counting application
	See "Straight weighing"

2.4.4 Application → Over/Under

Overview

Level 1	Level 2	Level 3
Tolerance type	Off , Absolute, Relative, Percent	
Default values	Act. deflt. values	Off , On
	Rel. weight	Tol -, Tol +
	Per. weight	Tol -, Tol +
	Rel. pieces	Tol -, Tol +
Output	Thresh % of tol-	
	Beeper	Off , Within Tolerances, Outside Tolerances
	Beeper mode	Continuous, Stable
	Autoprint	Off , Within Tolerances, Outside Tolerances
Disp.mode&color	Stealth mode	Off, On
	Good range	Yellow, Light blue, Dark blue, Red, Purple, Green, Orange, Light green, Pink, White
	Under range	
	Over range	
	Below threshold	
Printout	see "Straight Weighing"	

Description

Tolerance type	Specifying which parameters have to be entered for Over/Under Checkweighing/ Filling
Off	No tolerance type predefined, it can be set individually when entering Over/Under Checkweighing/Filling parameters.
Absolute	A low and a high weight value must be entered. These weights and all weights within this range are treated as being within tolerance.
Relative	The target weight has to be entered as an absolute weight, upper and lower tolerances as deviations in weight from the target weight.
Percent	The target weight has to be entered as an absolute weight, upper and lower tolerances as deviations in percent from the target weight. This setting is not available for counting.
Default values	Storing default tolerance values
	If you always use the same tolerances for Over/Under Checkweighing, you can store these tolerances and thus avoid entering tolerances all the time.
Act. deflt. values Off On	Activating usage of default tolerance values. Default tolerance values not used Default tolerance values used
Rel. weight	Entering the default values for Tolerance – and Tolerance +.
Per. weight	Entering the default percentages for Tolerance – and Tolerance +.
Rel. pieces	Entering the default values for Tolerance – and Tolerance + in pieces.

Output	Setting output options
Thresh % of tol- Off Within tolerances Outside tolerances	When Thresh % of tol- is reached, the colored display will change from the "Below threshold" color to the "Tolerance –" color. This feature can be used to show the "Tolerance –" color when you are already near the target Possible settings 0 ... 100 % (of the "Tolerance –" value) Factory setting 12 %
Beeper Off Within tolerances Outside tolerances	Setting the beeper for Over/Under Checkweighing No beeper A short beep will sound when a weight value within the tolerance values is reached A short beep will sound when a weight value outside the tolerance values is reached
Beeper mode Continuous Stable	Defining how the beeper will act Beeping on every change in weight within the selected range Beeping only when a stable weight value within the selected range is recognised
Auto print Off Within tolerances Outside tolerances	Setting the automatic printout No automatic printout Automatic printout when a stable weight value within the tolerance values is reached Automatic printout when a stable weight value outside the tolerance values is reached
Display mode & colors	Setting the weight display in the Over/Under Checkweighing application
Stealth mode Off On Good range Under range Over range Below threshold	This menu item is not available if the scale is approved. Weight display No weight display, only the colored display for "too light", "good" and "too heavy". Selecting the color to indicate a weight value within tolerances Factory setting: green Selecting the color to indicate a weight value below "Tolerance –" Factory setting: red Selecting the color to indicate a weight value above "Tolerance +" Factory setting: yellow Selecting the color to indicate a weight value below "Threshold as % of Tol –" Factory setting: white
Printout	Defining printer and template in the Over/Under Checkweighing application
	See "Straight weighing"

2.4.5 Application -> Totalizing

Overview

Level 1	Level 2	Level 3	Level 4
Mode	Mode	Manual , Auto +, Auto -	
	Zero return	Off , On	
Printout	Lot print	COM1, COM2	Off, Standard, Template 1 ... Template 10
	Final print		
	Summary print		

Description

Mode	Configuring totalising
Mode	
Manual	Items must be totalized manually with the soft key +
Auto +	Stable weight values will be totalized automatically
Auto -	Automatic totalizing of stable weight values in subtractive weighing
Zero return	Reaching a stable zero point between two items
On	All load must first be removed from the scale before totalizing of the next item is possible
Off	No load removal requested between two items
Printout	Configuring printouts
Lot print	Printout for each individual item
Final print	Printout of the total at the end of totalising
Summary print	Additional printout of the individual items and the total after completion of totalizing.
COM1, COM2	Selecting the printer interface for the lot printout
Off	No automatic printout
Standard	Automatic printout using the standard template which is predefined in the factory.
Template 1 ...	Automatic printout using the selected template
Template 10	

2.4.6 Application -> Memory

Custom field	Selecting information to be stored with the alibi data record in the additional custom field Select from the following: Off, Ter. model, Ter. loc., Article, Article descrip., ID1, ID2, ID3, APW, Qty, Ter. SNo.
---------------------	---

2.4.7 Application -> Database

Description field	
Off	No field for entering a description.
On	Each data record has an additional field to enter, e.g., an article name
Delete record	Select a data record to be deleted.
Delete all	Delete all data records. A safety prompt is displayed.
Print all	Print all data records.

2.4.8 Application -> Prompting

App	Selecting the workflow which shall be supported by the prompt
Tare / Sample	Reference determination: First tare, then add reference parts
Sample / Tare	Reference determination: First weigh reference parts, then tare
Handsfree	Counting without a keystroke
Take away	Over/Under Checkweighing out of a container without pressing any key
Multi tare	Taring of several containers with the same tare weight
Additive tare	Adding the known tare weight of different containers

2.4.9 Application -> Reset – Resetting application settings to factory settings

Perform reset ?	Confirmation inquiry <ul style="list-style-type: none"> Reset the application settings to factory settings with OK.
------------------------	---

2.5 Terminal menu block

The Terminal menu block consists of the following main subblocks, which are described in detail in the following.

- Device
- Access
- Reset

Factory settings are printed in **bold** in the following overview.

2.5.1 Terminal -> Device – General device settings





Overview

Level 1	Level 2	Level 3	Level 4	Level 5
Region	Language	English , US English, Deutsch, Français, Italiano, Español, Chinese, ...		
	Date format	MM/DD/YY, MM/DD/YYYY, MMM/DD/YYYY, DD/MM/YY, DD/MMM/YYYY, YY/MM/DD, YYYY/MMM/DD, YYYY/MM/DD, DD/MM/YYYY		
	Set date	Set year		
		Set month		
		Set day		
	Time format	24:MM, 12:MM tt, 24:MM:SS , 12:MM:SS tt		
Set time	Set hour			
	Set minutes			
Sleep	Off , 1 minute, 3 minutes, 5 minutes, 15 minutes, 30 minutes			
Identification	SNo. Ter., Terminal Model, Terminal loc., Terminal ID			
Display	Display layout	Default , 3-line mode, Color mode		
	Contrast	1 ... 5 ... 10		
	Brightness	1 ... 10		
	Weight hold	0 s ... 10 s		
	Default color	Yellow, Light blue, Dark blue, Red, Purple, Green, Orange, Light green, Pink, White		
	Auxiliary line	Not used, Date & Time, Gross, Net, Tare, High resolution (not available for approved scales), ID1, ID2, ID3, Target, Tolerance+, Tolerance-, Dev. to target, APW, Reference count, Quantity, Article name, Article desc., Total net, Total gross, Total PCS, Lot, Bargraph		

Level 1	Level 2	Level 3	Level 4	Level 5	
Keyboard	Hard keys	Power, Clear, Switch, Info, Transfer, Numeric keys	Off, On		
	Soft key	Soft key 1-1 ... Soft key 4-4	Not used, Zero, Tare, High Resolution, Avg. weighing, ID1, ID2, ID3, Prompt, Alibi Memory, Switch scale, Ref N, Ref N fix, APW, APW opt., Weight count, Totalizing, Over/Under, Save article, Recall article, Display layout		
	Info key	Page 1	Item 1 ... Item 5	Not used, Date & Time, Highres & net, Gross, Net, Tare, ID1, ID2, ID3, Terminal ID, Terminal loc., Terminal model, SNo. Terminal, Terminal FW, SNo. Scale, Scale FW, Target, Tol-, Tol+, Dev. to target, APW, Quantity, Article name, Article desc., Total gross, Total net, Total PCS, Lot, MinWeigh, IP address, Subnet mask, Gateway	
			Page 2 & 3	Info page 2	Off, System info , Contact info
			Info page 3	Off , System info, Contact info	
	Beeper	Off , On			
	Message time	1 s, 2 s , ... 6 s			
Timeout	Mode	Off , Rental, Rental info			
	Set date	Set year, Set month, Set day			

Description

Region	Country specific settings
Language	Selecting the language of the operator interface. We will expand the available languages continuously.
Date format	Selecting the date format
Set date	Entering the year in the selected format Entering the month in the selected format Entering the day in the selected format
Set year	
Set month	
Set day	
Time format	Selecting the time format
Set time	Entering the hour in the selected format Entering the minutes
Set hour	
Set minutes	
Sleep (Operator access)	Setting the sleep mode
Off 1 minute ... 30 minutes	This menu item only appears on devices in mains operation . When <code>Sleep</code> is activated, the device switches off display and backlighting after the time period set when not in use and gross weight is 0. Display and backlighting are switched on again by pressing a key or if the weight changes.
Identification	Setting terminal identification data
Sno. Terminal	Showing serial number of the weighing terminal
Terminal model	Showing the weighing terminal model, here: ICS466x
Terminal loc.	Entering the terminal location, e.g., floor and room
Terminal ID.	Entering the terminal identification, e.g., inventory number
Note	<ul style="list-style-type: none"> Terminal location and terminal identification can be displayed in the auxiliary or info lines or printed out. Terminal location and terminal identification can consist of up to 12 characters (0 ... 9 and decimal point)

Display	Setting the display according to your specific task
Display Layout	Selecting the presentation of the weight value.
Contrast (Operator access)	Setting the contrast of the display. This menu item is accessible with Operator access rights.
Brightness (Operator access)	Setting the brightness of the display. This menu item is accessible with Operator access rights.
Weight hold	Setting how long (in seconds) the weighing result will be frozen in the display after the transfer key  has been pressed or auto print was generated.
Default color	Setting the default color for straight weighing.
Auxiliary line	Selecting the contents of the auxiliary display line.
Keyboard	Setting the keyboard according to your specific task
Hard keys	Locking/unlocking keys. Possible keys Power (), Clear (C), Switch / Toggle (), Info (i), Transfer (), Numeric keys
Soft keys Soft key 1-1 ... Soft key 4-4	Assigning a function to the selected key. 1. Select the soft key number 2. Assign function
Info key Page 1 Page 2, Page 3	Configuring the items to be displayed using the info key (i) On the first page of the info key up to 9 information items on the weighing process can be configured. 1. Select item number 2. Assign information On pages 2 and 3 system and contact information will be displayed. In case of a problem, here you will find your contact data and the system information the service technician will ask for. System information is set by the manufacturer, contact information is set by your sales representative.
Beeper	When set to On, each keystroke will be confirmed by a short beep.
Message time	Setting how long a message is displayed
1, 2, 3, 4, 5, 6	Setting how long a message is displayed in seconds.

Time out	Setting the behaviour when no action takes place on the terminal
Mode	Setting the time out mode.
Off	No time out setting.
Rental	The scale can only be used until a set date, e.g., when the scale is rented for a special event like a fair or a market. After the expiration date a message is displayed: "Rental expired" and the scale can no longer be used.
Rental info	When the set date has passed, a message is displayed: "Rental expired". By pressing the key C , the message is cleared and the scale can be used as before.
Set date	Entering the expiration date.
Set year	Entering the year of the expiration date
Set month	Entering the month of the expiration date
Set day	Entering the day of the expiration date

2.5.2 Terminal → Access – Password for Supervisor menu access

Supervisor	Password for Supervisor menu access
Password	Enter password for Supervisor menu access.
Retype Password	Repeat the password entry.
Note	The password can consist of up to 4 characters.

2.6 Communication menu block



- A printer or a computer in the safe area must be connected via a communication module, refer to the ICS466x Guide for Installers.
- For detailed information on interface protocols and commands refer to the SICS Reference manual.

The Communication menu block consists of the following subblocks:

Overview	Showing the interfaces installed.
COM1	Parameter settings for the standard RS232 interface COM1.
COM2	Parameter settings for the optional second communication interface COM2.
Define templates	Defining templates to be assigned to the application specific printouts

The interfaces identify themselves. Therefore only those menu settings appear which are relevant for the individual interface.

If no optional interface is installed, the COM2 menu will not appear.

2.6.1 Communication menu blocks for serial interfaces

Overview RS232/CL20mA menu block (COM1 / COM2)

Level 1	Level 2	Level 3	Level 4
Mode	Print, Auto print, Dialog , Continuous (Dialog), External input, Toledo Cont.-weight, Toledo Cont.-count, Second display, Digital scale		
	Digitol B, Digitol G	Net Gross Tare	Off , On
Printer	Type	ASCII printer , Label printer	
	ACII Format	Line format	Multiple , Single, Fixed
		Line length	1 ... 24 ... 100
		Separator	. , : ; - _ / \ Space
		Add line feed	0 ... 9
External input	Preamble length		
	Data length		
	Postamble length		
	Termination char.	CR, LF, EOT, ...	
	Destination	Off , Tare preset, ID1 ... ID3, APW, Article	
Parameter	Baud	300, 600, ... 9600 , ... 115200 baud	
	Parity	7 none, 8 none , 7 odd, 8 odd, 7 even, 8 even	
	Handshake	Off , Xon - Xoff	
	Checksum	Off , On	
	STX	Off , On	
Reset RS232	Perform Reset ?		



CL20mA interface is only available via a communication module in the safe area.

Overview RS422 / RS485 menu block (COM2)

Level 1	Level 2	Level 3
Mode	see RS232	
Printer		
External input		
Parameter	Baud	300, 600, ... 9600 , ... 115200 baud
	Parity	7 none, 8 none , 7 odd, 8 odd, 7 even, 8 even
	Handshake	Off , Xon - Xoff
	RS-Type	RS422 , RS485
	Net address	0 ... 31
	Checksum	Off , On
Reset RS4xx	Perform Reset ?	



The RS422 / RS485 interface is only available via a communication module in the safe area.

2.6.2

Description of the communication menu blocks for serial interfaces

Communication → COMx → Mode – Operating mode of the serial interface

Print	Manual data output to the printer with 
Auto print	Automatic output of stable results to the printer (e.g., for series weighing operations)
Dialog	Bi-directional communication via MT-SICS commands, control of the device via PC
Continuous (Dialog)	Ongoing output of all weight values via the interface
External input	Input other than via terminal keypad. What the input is used for is defined in the <i>Destination</i> menu block
Toledo Cont.-weight	TOLEDO Continuous mode
Toledo Cont.-count	TOLEDO Continuous mode with counting results
Second display	On the selected interface port a second display is installed
Digital scale	On the selected interface port a digital scale is connected
Digital B, Digital G Net, Gross, Tare	<p>Digital compatible format. The gross weight is identified either by "B" or by "G".</p> <p>Selecting the weight values to be transferred.</p>
Note	<p>Printing conditions for <i>Auto print</i> and <i>Demand m auto</i>:</p> <ul style="list-style-type: none"> • The weight must be heavier than 9 display increments. • A weight change of at least 9 display increments is required to initiate the next printout.

Communication -> COMx -> Printer - Settings for protocol printout

Type	Selecting printer type
ASCII printer Label printer	Note If Label printer is selected, the transmitted data does not include the name of the variable, e.g., date, gross, ID1, but the value and, if appropriate, the unit as a separate line. This allows the label printer to fill its template with the required data.
ASCII Format	Selecting formats for the protocol printout
Line format Multiple Single Fixed	Selecting line format: Multiple lines Single line Fixed (Records output in single lines; every record includes the number of characters that was defined under <i>Line length</i>)
Line length	Setting line length This item is only displayed for the line formats <i>Multiple</i> and <i>Fixed</i>
Separator	Selecting the separator This item is only displayed for the line format <i>Single</i>
Add line feed	Adding line feeds

Communication -> COMx -> External input - Configuring barcode input

Preamble length	The barcode may contain additional data ahead of the relevant data (preamble) and behind (postamble). → Enter the number of characters of preamble, (relevant) data and postamble
Data length	
Postamble length	
Termination char.	Selecting the termination character which is used by the connected barcode scanner
Destination	Selecting the item to be entered via barcode scanner

Communication → COMx → Parameter – Communication parameters

Not all parameters are available on all serial interfaces. Refer to the overviews of the interfaces to check which parameters are available.

Baud	Selecting baud rate
Parity	Selecting parity
Handshake	Selecting handshake
Checksum	Activating/deactivating checksum byte
STX	Activating/deactivating STX If STX is enabled, the STX signal (0x02) is sent at the beginning of each output string that is sent via the interface.
RS Type	Selecting type of the optional RS422/RS485 interface
Net Address	Assigning network address

2.6.3**Communication – Define templates**

Level 1	Level 2	Level 3
Template 1 ... Template 5	Line 1 ... Line 30	Not used, Header *, Date, Time, Gross, Net, Tare, High resolution, ID1, ID2, ID3, Terminal ID, Terminal loc., SNo. Terminal, SNo. Scale, Star line, New line, Form feed, Target, Tolerance -, Tolerance +, Tolerance type, Deviation, Weight position, Average PW, Reference count, Quantity, Article, Article descrip., (Alibi) Record number

* The content of these items has to be entered via SICS command.

Configuring templates

1. Select a template.
2. Select a line.
3. Assign an item.



There are 5 more templates available (Template 6 ... Template 10). Please ask your METTLER TOLEDO service technician to configure these templates.

2.7 Maintenance menu block

2.7.1 Overview

Level 1	Level 2	Level 3	Level 4
Scale test	Scale 1 Scale 2	External test	Perform test?
		Conf. ext. test	Test weight
			Weight name
	Auto print	On, Off	
Keyboard test	Perform test?		
Display test	Perform test?		
Serial no.	SNo. scale		
	SNo. terminal		
Print setup	Print menu settings?		
Tool comm.	Port		
	Baudrate		
	Start		
Reset all	Perform reset?		

2.7.2 Description

Scale test	Testing the selected scale
External test	<p>For scales without an internal test weight Before performing an external test for the first time, the test weight must be configured under Conf. ext. test.</p> <ol style="list-style-type: none"> Press the soft key OK to start the test. Preload is displayed. If applicable, load the preload and press the soft key OK. The test weight is blinking. Load the requested test weight and press the soft key OK. The deviation of test weight value and actually weighed value is displayed.
Perform test?	
Conf. ext. test	Configuring the external test weight
Test weight	Setting the test weight value
Weight name	Entering the test weight name
Tolerance	Setting the test tolerance
Auto print	Activating/deactivating the automatic printout of the scale test result

Keyboard test	Testing the keyboard
Perform test?	<ol style="list-style-type: none"> 1. Press the soft key OK to start the keyboard test. 2. Press the keys in the displayed order. If the key works, the device switches to the next key. The keyboard test is terminated by pressing .
Display Test	Testing the display
Perform test?	<ol style="list-style-type: none"> 1. Press the soft key OK to start the display test. A checkerboard pattern is displayed. 2. Press any key to invert the checkerboard pattern. 3. Press any key to show the colored display. 4. Repeat pressing a key until "Perform test?" is displayed again. <p>The display is working properly if all fields are displayed without missing pixels.</p>
Serial number	Displaying serial numbers
SNo. scale	Displaying the serial number of the connected weighing platform.
SNo. terminal	Displaying the serial number of the weighing terminal.
Print Setup	Printout of a list of all menu settings
Print menu settings	→ Press OK to start the printout.
Tool comm.	Testing the communication
Port	Selecting the COM port to be tested
Baudrate	Setting the baudrate for testing
Start	Start tool communication test
Reset All	Reset all settings to factory settings
Perform reset ?	<p>Confirmation inquiry</p> <ul style="list-style-type: none"> • Reset all settings to factory settings with OK.

3 Technical data and accessories

3.1 Technical data

Housing	<ul style="list-style-type: none"> Stainless steel
Display	<ul style="list-style-type: none"> Monochrome LCD graphical display, with colored backlighting
Keyboard	<ul style="list-style-type: none"> Tactile-touch membrane keypad (PET) Scratch-resistant labelling
Protection type	<ul style="list-style-type: none"> IP65
Net weight	<ul style="list-style-type: none"> Weighing terminal 2.8 kg / 6.1 lb
Mains connection	<ul style="list-style-type: none"> Via APS768x
Ambient conditions	<ul style="list-style-type: none"> Application indoor use only Altitude up to 2,000 m Temperature range Class II/III -10 ... 40 °C / 14 ... 104 °F Humidity: Max. rel. humidity 85 % for temperatures up to 40 °C
Ignition protection type	<p>EN/IECEx</p> <ul style="list-style-type: none"> II 2G Ex ib IIC T4 Gb, -10 °C ... +40 °C II 2D Ex ib IIIC T60°C Db IP65 <p>FM_{us}</p> <ul style="list-style-type: none"> IS Class I, II, III; Division 1; Group A, B, C, D, E, F, G; T4; Ta = 40 °C AEx ib IIC T4; IP65; Type 4
Interfaces	<ul style="list-style-type: none"> 1 interface RS232-IS and 1 scale interface integrated 1 additional optional communication interface possible 1 additional optional scale interface possible
W & M approvals	<ul style="list-style-type: none"> OIML Class II, III, IIII NTEP Class II, III

Applications

- Weighing
- Average weighing
- Over/Under Checkweighing
- Counting
- Totalizing
- Database
- Prompting
- Alibi Memory

Analog scale interface

Impedance	<ul style="list-style-type: none"> • 80 ... 3,000 Ω
Excitation	<ul style="list-style-type: none"> • 3.3 V
Sensitivity	<ul style="list-style-type: none"> • up to 3 mV/V
Max. resolution	<ul style="list-style-type: none"> • 10,000 e (OIML) • 300,000 d (non approvable)
Min. verification interval	<ul style="list-style-type: none"> • 0.26 $\mu\text{V}/\text{e}$

Dimensional drawing

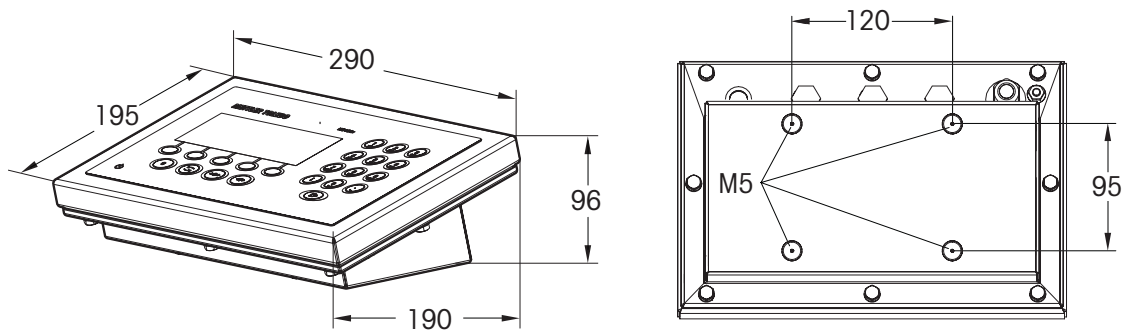

3.2

Accessories

Accessories	Order no.
ICS466x digital scale IF kit	30 076 833
ICS466x active CL IF kit	30 076 831
ICS466x passive CL IF kit	30 076 830
ICS466x sealing kit	30 076 829
ICS466x bracket kit	30 076 832
Column, stainless steel Height 330 mm / 1.3 ft Height 660 mm / 2.6 ft	22 010 334 22 010 335
Column adapter	22 015 188
ICS466x column kit K...x-T4	22 026 682
ICS466x compact scale kit K...x-T4	22 026 683
Floor stand, height 1000 mm / 3.3 ft, stainless steel	00 504 132
Stand base, stainless steel	00 503 701
Wall bracket, stainless steel	00 504 130
Bench stand, stainless steel	00 504 128
Retainer, stainless steel	22 012 196
APS768x power supply APS768x-230 V APS768x-120 V	22 021 262 22 021 261
ACM200 interface converter ACM200-AC ACM200-DC	22 016 767 22 023 347

4 Appendix

4.1 Notice for verified instruments in EC countries



Weighing instruments verified at the place of manufacture bear the preceding mark on the packing label and a green "M" sticker on the descriptive plate. They may be set to work immediately.



Weighing instruments which are verified in two steps have no green "M" on the descriptive plate and bear the preceding identification mark on the packing label. The second step of the verification must be carried out by the approved METTLER TOLEDO service or Weights and Measures authorities. Please contact your METTLER TOLEDO organisation. The first step of the verification has been carried out at the manufacturing plant.

If national regulations in individual countries limit the period of validity of the verification, the operator of such a weighing instrument is himself responsible for its timely re-verification.

4.2 Tables of Geo Code values

For weighing instruments verified at the manufacturer's, the Geo Code value indicates the country or geographical zone for which the instrument is verified. The Geo Code value set in the instrument (e.g. "Geo 18") appears briefly after switching on.

Table "Geo Code values 3000e" shows the Geo Code values for European countries.

Table "Geo Code values 6000e/7500e" shows the Geo Code values for different gravitation zones.

4.2.1 Geo Code values 3000e, OIML Class III (European Countries)

Country	Geographical latitude	Geo Code value
Austria	46°22' – 49°01'	18
Belgium	49°30' – 51°30'	21
Bulgaria	41°41' – 44°13'	16
Croatia	42°24' – 46°32'	18
Czechia	48°34' – 51°03'	20
Denmark	54°34' – 57°45'	23
Estonia	57°30' – 59°40'	24
Finland	59°48' – 64°00'	25*
	64°00' – 70°05'	26
France	41°20' – 45°00'	17
	45°00' – 51°00'	19*
Germany	47°00' – 55°00'	20
Greece	34°48' – 41°45'	15
Hungary	45°45' – 48°35'	19
Iceland	63°17' – 67°09'	26
Ireland	51°05' – 55°05'	22
Italy	35°47' – 47°05'	17
Latvia	55°30' – 58°04'	23

Country	Geographical latitude	Geo Code value
Liechtenstein	47°03' – 47°14'	18
Lithuania	53°54' – 56°24'	22
Luxemburg	49°27' – 50°11'	20
Netherlands	50°46' – 53°32'	21
Norway	57°57' – 64°00'	24*
	64°00' – 71°11'	26
Poland	49°00' – 54°30'	21
Portugal	36°58' – 42°10'	15
Romania	43°37' – 48°15'	18
Slovakia	47°44' – 49°46'	19
Slovenia	45°26' – 46°35'	18
Spain	36°00' – 43°47'	15
Sweden	55°20' – 62°00'	24*
	62°00' – 69°04'	26
Switzerland	45°49' – 47°49'	18
Turkey	35°51' – 42°06'	16
United Kingdom	49°00' – 55°00'	21*
	55°00' – 62°00'	23

* factory setting

4.2.2

Geo Code values 6000e/75000e OIML Class III (Height ≤ 1000 m)

Geographical latitude	Geo Code value
00°00' – 12°44'	18
05°46' – 17°10'	21
12°44' – 20°45'	16
17°10' – 23°54'	18
20°45' – 26°45'	20
23°54' – 29°25'	23
26°45' – 31°56'	24
29°25' – 34°21'	25*, 26
31°56' – 36°41'	17, 19*
34°21' – 38°58'	20
36°41' – 41°12'	15
38°58' – 43°26'	19
41°12' – 45°38'	26

Geographical latitude	Geo Code value
43°26' – 47°51'	18
45°38' – 50°06'	22
47°51' – 52°22'	20
50°06' – 54°41'	21
52°22' – 57°04'	24*, 26
54°41' – 59°32'	21
57°04' – 62°09'	15
59°32' – 64°55'	18
62°09' – 67°57'	19
64°55' – 71°21'	18
67°57' – 75°24'	15
71°21' – 80°56'	24*, 26
75°24' – 90°00'	18

* factory setting

4.3



Disposal

In conformance with the European Directive 2002/96 EC on Waste Electrical and Electronic Equipment (WEEE), this device may not be disposed of with domestic waste. This also applies to countries outside the EU, according to their specific requirements.

→ Please dispose of this product in accordance with local regulations at the collecting point specified for electrical and electronic equipment.

If you have any questions, please contact the responsible authority or the distributor from which you purchased this device.

Should this device be passed on to other parties (for private or professional use), the content of this regulation must also be related.

Thank you for your contribution to environmental protection.

4.4 Protocol printouts

P25 printouts, in English

Straight weighing – standard template

Gross	255 g	Gross/net/tare weights
Net	94 g	
Tare	161 g	

Starline

Average weighing with header and identification data

METTLER TOLEDO		Header
Tel. +49 7431 140		
Germany		
Date	07/05/2012	Date/time
Time	17:26:56	
ID1	Company ABC	Identifications
ID2	ID1	
ID3	ID2	
Dev.Id	456	
Average G	236 g	Average weighing result

Piece counting with header and identification

METTLER TOLEDO		Header
Tel. +49 7431 140		
Germany		
Date	07/05/2012	Date/time
Time	17:35:39	
ID1	Company ABC	Identifications
ID2	ID1	
ID3	ID2	
Dev.Id	456	
Gross	756 g	Gross/tare/net weights
Tare	161 g	
Net	595 g	
APW	9 g	Reference weight data
Ref Cnt	10 PCS	Counting result
Quantity	63 PCS	

Over/Under Checkweighing

Date	05/02/2002	Date/time
Time	06:39:33	
Terminal model	DeviceNam	Identification
Gross	5.000 kg	Gross weight
Target	4.800 kg	Over/Under Checkweighing info
High	5.100 kg	
Low	4.500 kg	
Deviation	0.200 kg	

4.5 Index

C		M		T	
Counting	16	Menu		Tare	
Autosampling	17	Application	15	Automatic clearing	10, 13
Auxiliary scale	18	Communication	27	Automatic taring	10, 13
Bulk scale	18	Operation	5	Chain tare	10, 13
Reference scale	18	Password	5	Technical data	35
Reference weight check	17	Scale (analog)	8	Templates	15, 32
D		Scale (IDNet)	12	Test	
Dimensions	36	Terminal	23	Display	34
Display		Mode		Keyboard	34
Auxiliary line	26	Dialog mode	30	Scale	33
Disposal	40	Digitol	30	V	
Dynamic weighing	16	External input	30	Verified instruments in EC	
E		Print mode	30	countries	38
Environment	35	Second display	30	Z	
External input	31	Toledo Continuous	30	Zero	
G		P		Automatic zero update	10, 13
Geo value	38	Power supply	35		
I		Printout examples	41		
Identifications	25	Prompting	22		
Info key	26	S			
Interface settings	27	SICS			
RS232	28	Command set	27		
RS422 / RS485	29				

METTLER TOLEDO Service

To protect your METTLER TOLEDO product's future:

METTLER TOLEDO Service assures the quality, measuring accuracy and preservation of value of all METTLER TOLEDO products for years to come.

Please send for full details about our attractive terms of service.
Thank you.

www.mt.com/service

For more information

Mettler-Toledo (Albstadt) GmbH

D-72458 Albstadt

Tel. +49 7431-14 0

Fax +49 7431-14 232

Subject to technical changes

© 10/2013 Mettler-Toledo (Albstadt) GmbH

Printed in Germany

Order number 22026632A



* 2 2 0 2 6 6 3 2 A *